

SECTION B-B

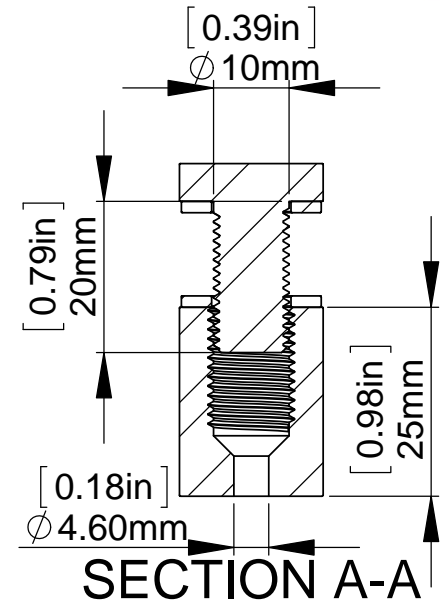

Item	Qty.	Description
1	1	SBL19-25 Body (19x25)
2	1	SBL19 Head
3	2	SBL19 Washer

Title : SBL19-30		Scale : 1:1		Mbs R&D	
		Sizes : Letter Landscape		Customer:	
Material:		Finish		Qty :	Rep :
N°programme laser		N°prog. Mécanum.		N° Plan : SBL19-30	

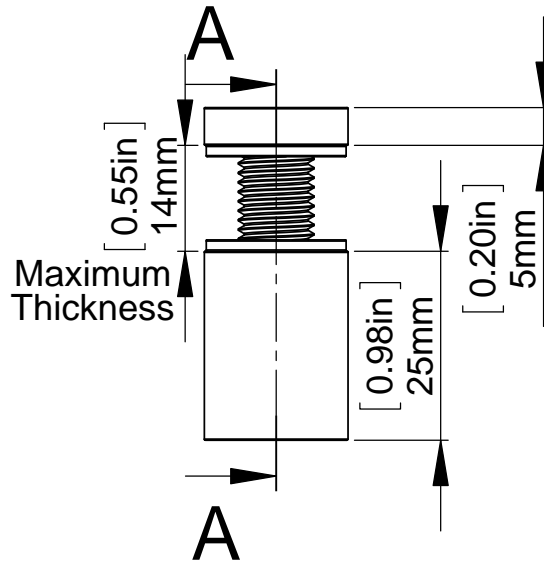
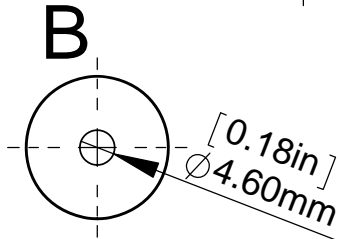
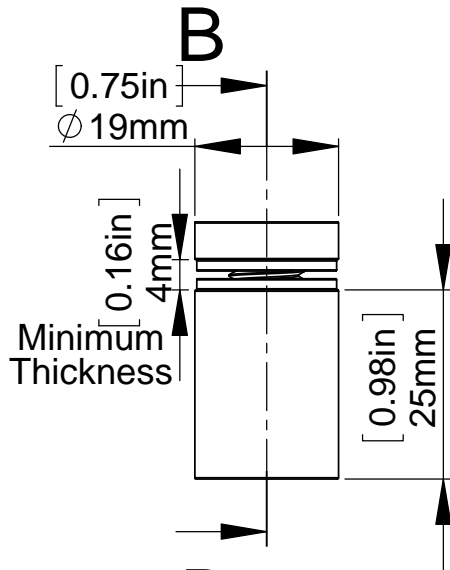

MBS Sign USA
Tel.: 352-593-4151
Fax: 352-796-4437
Brooksville, FL